

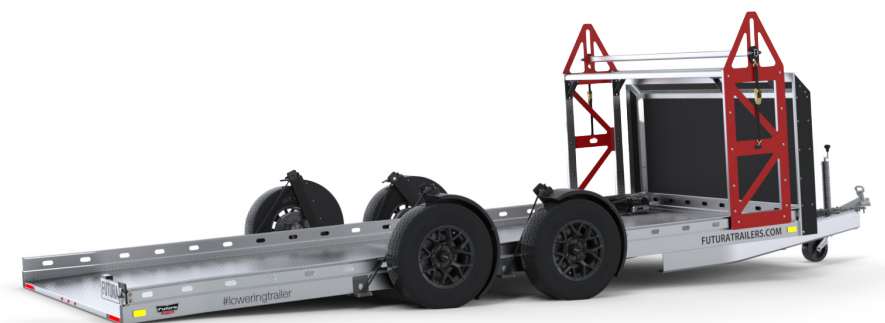

Sport Range Lowering Trailer Manual

AU/NZ



Email: trailers@futuratrailers.com

Phone: +64 9 415 2563

READ BEFORE USING YOUR FUTURA TRAILERS PRODUCT

RELEASE OF LIABILITY AND ASSUMPTION OF RISK AGREEMENT

By using any Futura Trailers product, you acknowledge that you have carefully read and fully understand the contents of the product's Owner's Manual available at www.Futuratrailers.com, including all instructions and warnings contained therein, before using the product. You agree to ensure that both you and any other user of your Futura Trailers product will read, understand and agree to this Release of Liability, Assumption of Risk, and Claim Waiver before using the product.

ASSUMPTION OF RISK: The use of the Futura Trailers product and its components inherently involves risks, dangers and hazards that can cause serious injury or death to users and non-users. By using this product, you freely assume and accept all known and unknown risks, damages and injuries to yourself and others or property while using the equipment. The risks can be significantly reduced by following the warning guidelines listed in the Manuals and using common sense.

WAIVER OF CLAIMS: In consideration of the sale of the Futura Trailers product, you unconditionally and irrevocably agree to waive any claims that you have or may have in the future against Futura Trailers Inc, Futura Trailers Ltd and all related parties resulting directly or indirectly from the use of the Futura Trailers product and any of its components.

RELEASE AND WAIVER OF LIABILITY: You agree to release and hold harmless Futura Trailers Inc, Futura Trailers Ltd and all related parties from any liability for any loss, damage, injury, or expense that you or any user of your Futura Trailers product may suffer due to the use of the product, regardless of the cause of such loss, damage, injury or expense, including negligence or breach of contract on the part of Futura Trailers Inc, Futura Trailers Ltd, and all related parties in the design or manufacture of the product and any of its components.

INDEMNITY: In further consideration of the sale of the Futura Trailers product and as a separate obligation, you agree to indemnify Futura Trailers Inc, Futura Trailers Ltd and all related parties to the maximum extent permitted by law from any claims, proceedings, liabilities, costs, damages, and expenses they may suffer or incur as a direct or indirect result of your use of the product or the use of the product by any third party. The provisions contained herein will remain effective and binding upon your heirs, next of kin, executors, administrators, assignees, and representatives in the event of your death or incapacity. Futura Trailers Inc and Futura Trailers Ltd-related parties make no oral or written representations other than those set forth herein.

Welcome to Futura Trailers

Welcome to the Futura family! At Futura Trailers, we take pride in our quality and aim for your satisfaction. If you encounter any issues, contact our After Sales team at +64 9 415 2563 or trailers@futuratrailers.com.

This manual is your safety and usage guide. Familiarize yourself with it for a safe towing experience. For any queries, our After Sales team is here to help.

Before setting off, review the safety precautions and tips in this manual. They ensure both your safety, your trailer's longevity and maximum efficiency.

Your Futura lowering trailer is more than just a trailer; it's the key to unlocking unforgettable experiences. By adhering to this manual, you ensure your trailering experience is safe and effortless.

Thank you for choosing Futura Trailers. Safe travels!
Futura Team

View "Quick Start Guide" at www.futuratrailers.com/my-futura



Read before towing your trailer

CAUTION

Wheel separation can occur. For proper safety and performance the following checks should be performed at the specified intervals.

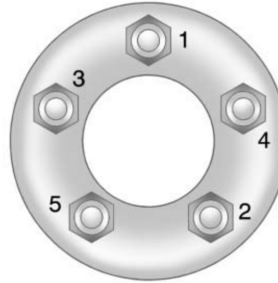

Check wheel nut torque to 95 ft/lb at 15, 50 and 100 km and before each tow.

Trailer wheel nuts are prone to loosen after first being assembled. When towing a new trailer, or after wheels have been remounted, check to make sure the wheel nuts are tight after the first 15, 50 and 100 km of driving and before each tow thereafter.

- Torque wheel nuts to 95 ft/lb in the sequence shown above.
- Repeat sequence before each trip or whenever a wheel is removed or replaced.

Check wheel bearings for heat or excessive play at 15, 50 and 100 km.

The wheel bearing play is set at the factory, however, the wheel bearings may need resetting after towing and should be checked regularly.

- Tow the trailer for 15 km at highway speeds.
- Stop the vehicle and park in a safe location.
- Place your hand on each of the wheel hubs of the trailer. If a hub is too warm to comfortably hold your hand on, the bearing is generating excessive heat and may be defective, have insufficient play or require lubrication.
- Setting wheel bearings please refer to the Service and Maintenance section of this manual.
- Check the wheel bearing for excessive heat or play again after 50 and 100 kms.

WARNING

Failure to follow these instructions may result in serious injury or death! Failure to follow these instructions may invalidate the product warranty.

Operating your Futura Lowering Trailer

This document is to be read in full. Learn how to safely and correctly operate the Futura lowering trailer. Instructional videos are available at futratrailers.com/my-futura



1. Connect the trailer to the tow vehicle

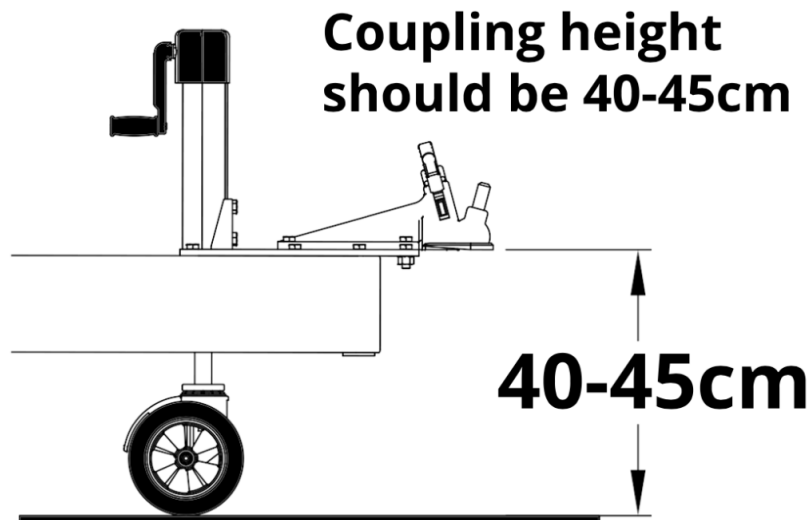

TOWBALL SIZE - NZ 1 7/8 ", AUS 50mm.

CAUTION

Dangerous trailer sway may occur if hitch height is too low.
Front lifting arm will not raise fully if hitch height is too low.

futratrailers.com

Operating your Futura Lowering Trailer

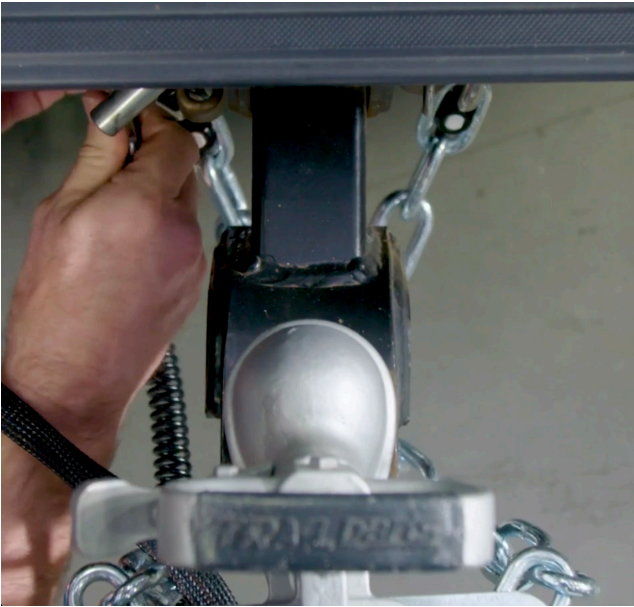

Connect to the tow vehicle. Ensure the safety cables and the break-away cable are securely connected to the tow vehicle.

Safety cables must be crossed under the hitch.



Crank up the jockey wheel completely until the wheel locks.

Tighten the crank to secure wheel and prevent accidental operation.

CAUTION

Ensure the tow ball size is correctly matched to the coupling.
Ensure safety cables are connected and crossed, jockey wheel is locked up and breakaway is connected to the tow vehicle.

Operating your Futura Lowering Trailer

Make sure to always use a safety pin on the trailer couling.

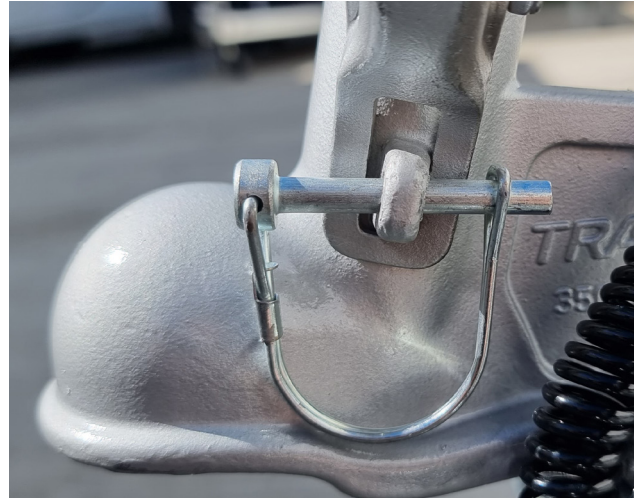
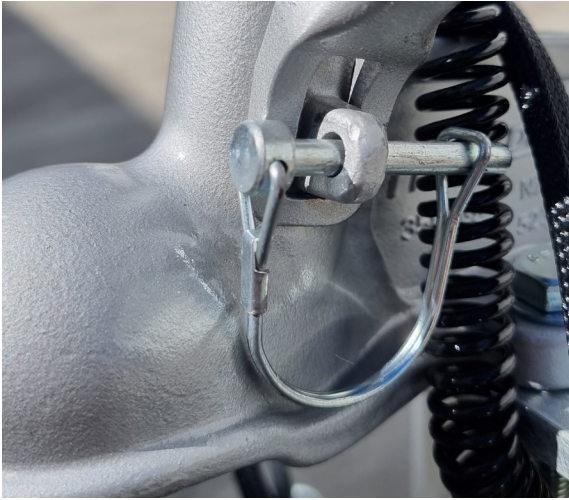

Always secure the safety chain to your vehicle.



WARNING

IMPTOPER TOW BALL CONNECTION COULD CAUSE THE TRAILER TO DISCONNECT UNDER LOAD. ALWAYS ENSURE PROPER CONNECTION

Operating your Futura Lowering Trailer

2. Park the trailer on level ground.

CAUTION

The trailer lifting arms may not raise fully if the trailer is not parked on level ground.

3. Lower the trailer.



Turn on your Futura **SmartControl** master switch to operate the trailer raising winch.



Before attempting to lower the trailer, release all of the safety latches.

Latch shown in un-locked position.

Operating your Futura Lowering Trailer



Turn on your **SmartControl** wireless remote by holding down the DOWN and OUT buttons simultaneously for 5 seconds until the red light illuminates.



Lower the trailer with the **SmartControl** wireless remote;

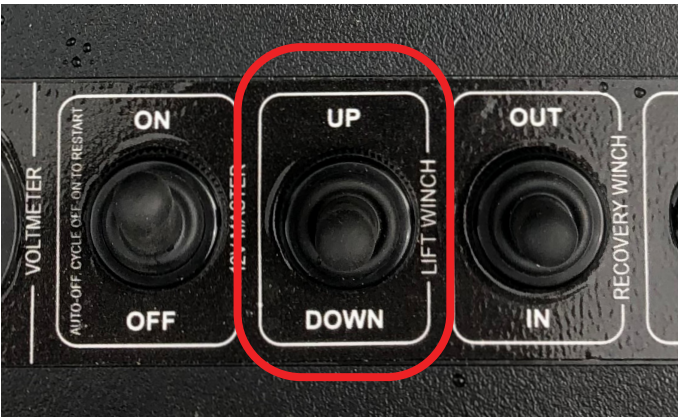

or - use the **SmartControl** manual switch to lower the trailer.

DANGER

Stand well clear of the trailer or remain in loaded vehicle while lowering or raising. There are several crush zones.
Never touch ropes or moving parts when in operation.

Operating your Futura Lowering Trailer

CAUTION

If you forget to unlock the safety latches before lowering the trailer, do not attempt to unlock the safety latches as they will be under load. Raise the trailer again, then release the safety latches.

The Futura **SmartControl** will sense when the trailer deck has lowered to the ground. The trailer raising mechanism will automatically disengage once the trailer deck has lowered to the correct level.

4. Raise the license plate.

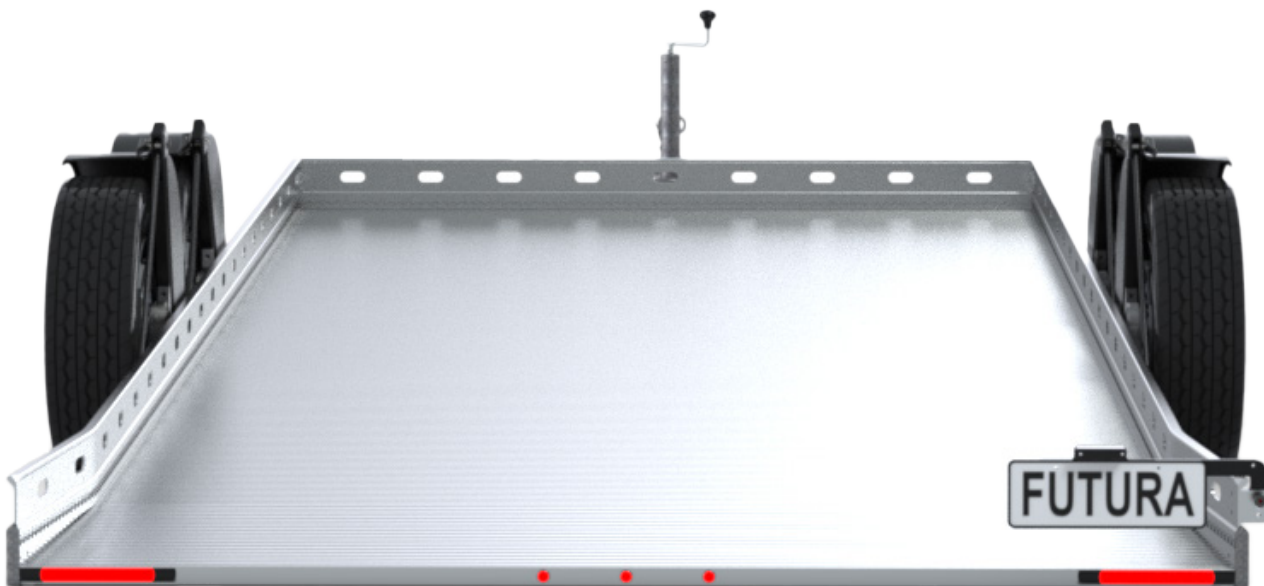

Operating your Futura Lowering Trailer



5. Roll, winch or drive the vehicle onto the trailer.

- Load the vehicle as far forward as possible.
- Ensure that at least 10% of the total weight is on the trailer tongue.
- Rear and mid engine cars may require loading backwards for correct load distribution.
- If you drive on take the remote with you. You may use the remote to raise the trailer from inside the vehicle.
- You may not be able to open your vehicle doors with the trailer lowered. Removing the drivers side fender will allow more space for a low car door to open.
- Be sure to check the fender is securely pinned back in place if it is removed for loading.



DANGER

Do not allow others to stand near the operating area or in an area where an unsecured vehicle might roll. Do not leave the trailer in the raised position unattended. Do not raise the trailer on uneven ground.

Operating your Futura Lowering Trailer

CAUTION

Latches must be in the open position as below when raising the trailer.
Damage may occur to the trailer if the latches are closed when raising.



6. Ensure all latches are in the unlatched position before raising the trailer using the Trailer remote or winch enclosure switch.

The trailer raising mechanism will stop automatically when the trailer is raised to the travelling position.

Once the trailer is raised, latch all four safety latches. Prior to towing it is important to check all safety latches are engaged.



CAUTION

Do not tow trailer without first ensuring the safety latches are all latched into place.
The load must remain on the ropes. Damage may occur to safety latches if travelling without tight ropes.

Operating your Futura Lowering Trailer

Charging the onboard battery

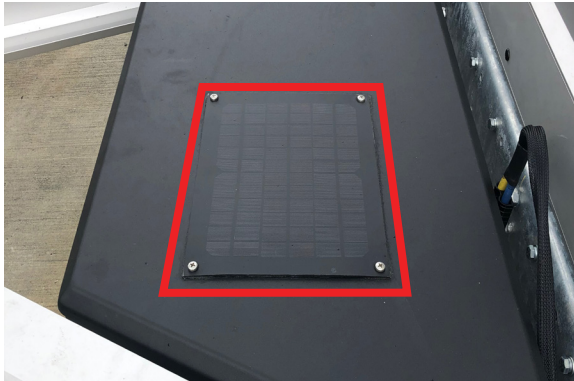

The trailer is equipped with a battery trickle charger which is powered by the tow vehicle auxiliary supply, if present on tow vehicle. The solar charger will operate in daylight to maintain the battery voltage.



A 110V power adapter is supplied with the trailer to charge the battery when the trailer is stored.

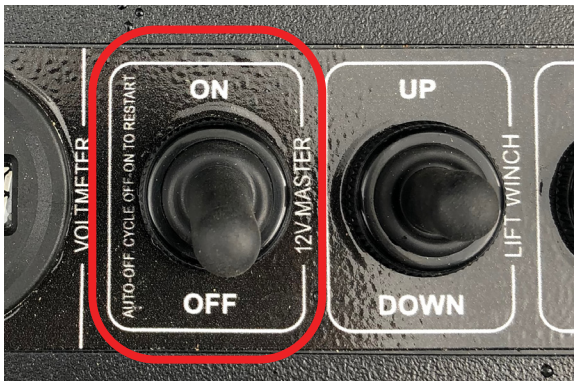

When the trailer is not in use, ensure the **SmartControl** master switch is turned off.

For security when not in use, lock the tool-box.

CAUTION

Ideal battery voltage is between 12.2V and 13V. Note:
The battery will be drained of charge if the breakaway switch is activated.
The trailer may not raise if the voltage is under 12.0V.

Loading your Futura Lowering Trailer

Futura lowering trailers are designed specifically for carrying motor vehicles. It is recommended that Futura over the wheel tie straps be used to secure the vehicle with the tie straps connected to the side chassis rails.

The vehicle must be loaded as far forward on the trailer as possible so the loaded tongue weight is 10% of the total load. Do not load cargo in the towed vehicle, once it is onboard the trailer as this may change the load distribution and overload the trailer.

For instruction on Futura over wheel tie straps, please see the video at futuratrailers.com/my-futura



WARNING

Do not exceed the load stated on the trailer's tire and loading information plate. Apply the towed vehicle park brake and always ensure towed vehicle is correctly secured to the trailer using Futura over wheel tie down straps before towing. Replace tie down straps if worn.

WARNING

Loaded tongue load must be 10% of total load. An incorrectly loaded vehicle may result in trailer sway or whipping and lead to a total loss of control. For correct weight distribution rear engine cars may require loading backwards.

CAUTION

If loading your trailer when not connected to the tow vehicle, use wheel chocks to ensure the trailer cannot move during loading and only load vehicle using the recovery winch. Have some tension on the cables to ensure load is taken on the tires. Stand clear while loading.

Important operating notice

Trailer raising mechanism, winch direction: If the trailer raising winch is over run in the down rotation the cable will re-spool and start to wind in, raising the trailer upwards.

The trailer will lift when the winch is run in the wrong direction. It will however not automatically stop when reaching the top of its travel. The proximity sensor is not wired to stop the winch when rotating in the down direction.

The trailer should only be raised by pressing UP button and lowered pressing the DOWN button.



Regularly inspect the rope rigging. Ensure the winch rope is always neatly spooled on the winch drum. If any ropes are frayed, replace them immediately. Spare parts can be ordered online at futuratrailers.com/my-futura

WARNING

Be aware of the importance of running the trailer winch in the correct rotation when raising and lowering the trailer.

If ropes fray replace immediately.



In case of trailer winch failure: If for any reason the winch fails to operate the trailer can be raised by placing a suitable jack under the mount beam and jacking from each side.

Secure the safety latches to hold the trailer in the raised position and tie the loose cable rigging up from dragging on the ground before towing to a repair agent.

CAUTION

**ENSURE THE SHIFTR CENTRE CAP IS POSITIONED
CORRECTLY WHEN FITTING WHEELS**



When fitting the SHIFTR Centre Cap on your Futura Trailer wheels, always check that it is positioned correctly.

It should be flush with the inside of the wheel, and the 5 black plastic points inside the grooves as pictured below.

SHIFTR[®]

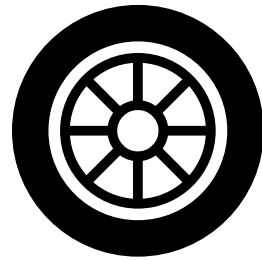

CAUTION

**CHECK FOR WINCH ROPE DAMAGE PERIODICALLY
UNDERNEATH THE TRAILER**

Periodic checks for wear and tear on the ropes are crucial to maintaining the integrity of your trailer.

Neglecting rope damage can lead to problems, risking vehicle damage and posing serious user risks.

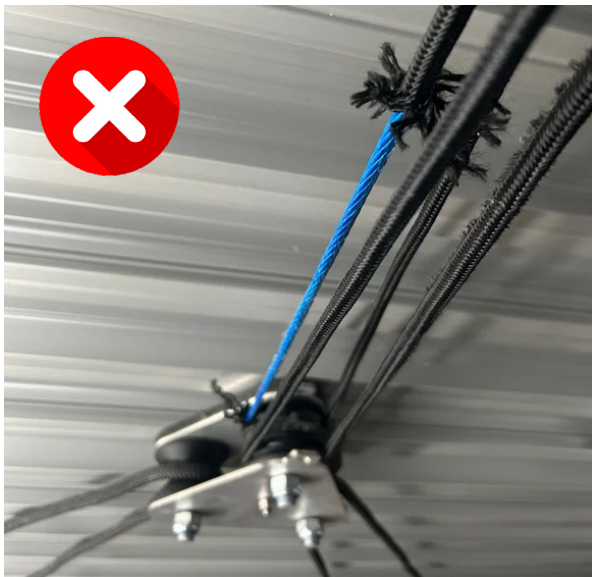

Super Tourer Enclosed



The sides should only be zipped open or closed when the trailer is fully raised and on level ground.

The sides and back door must be fully closed during transport. Do not travel with the sides or the backdoor open.

The zip slider should be closed to sit in a position either in front of, or behind, the fenders.

Do not close the zip sliders in line with the fenders. See below.



WARNING

Never travel with the sides or backdoor open. Do not tow the Futura Super Tourer enclosed in high wind conditions. Towing this trailer in high winds could result in loss of control and cause death or serious injury.

WARNING

Do not sleep inside the Super Tourer enclosed lowering trailer. Carbon Monoxide or other harmful vapors could enter the area through the floor openings, which could result in death or serious injury.

Storing your Futura Lowering Trailer

We recommend storing the trailer in the lowered position with the master switch off. Chock the wheels to prevent the trailer from rolling. The trailer can also be used for parking your vehicle on whilst in the lowered position.

CAUTION

Electric brake-away unit is for emergency brake-away function only. Do not use the brake-away unit as a park brake as the battery will run flat and the brakes will disengage.

WARNING

Enclosed trailers must be stored in the lowered position. Do not park the trailer outside while snowing or allow any type of debris to accumulate on the roof.

Marketing and Social Media

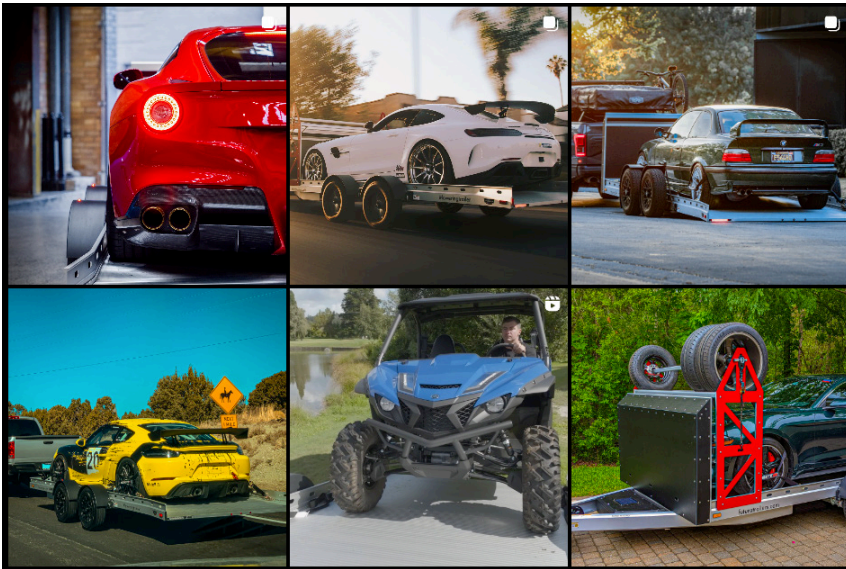

We love seeing our Lowering Trailers in action. Tag us in the fantastic photos you take with:

@futura Trailers or
#futura Trailers

If you see any photos you like on our social media pages or website, send us a message and let us know!



Service and Maintenance Summary

- Check wheel nut torque to 95 ft/lb at 15, 50 and 100 kms and before each tow.
- Check wheel bearings for heat and excessive play at 15, 50 and 100 kms and before each tow.
- Bed brakes in when first towing.
- Check brake adjustment 200 kms and 5,000 kms.
- Check drum brake pads for wear.
- Check tyre pressure before each tow (55psi).
- Lubricate wheel bearings every 12 months or 10,000 kms.
- Check lifting arm bearings regularly. There should be no back-lash in lifting arm bearings.
- Check lights are in working order.
- Check breakaway switch operation before each tow.
- Apply grease or motor cycle chain lube to shaft of the rigging pulleys regularly to prevent squeaking and prolong bearing life.
- Realign trailer winch cable on the winch drum if it gets crossed.
- Inspect winch rope and rigging wire and replace if there are any signs of damage or fraying.

WHEEL BEARING LUBRICATION SPECIFICATIONS

Thickener Type Lithium Complex

Dropping Point 215 C (419 F) Minimum

Consistency NLGI No 2

Additives EP, Corrosion and Oxidation Inhibitors

Viscosity Index 80 Minimum

DANGER

Tyre, wheel or wheel nut failure can cause loss of control. Before towing you must check tyre pressure and tread. Check tyres and wheels for damage.

Re-tighten wheel nuts for new and re-mounted wheels after first 15, 50 and 100 kms.

DANGER

Do not work under the trailer when it is loaded. Never get underneath the trailer unless it is securely supported by jack stands. Before working under the trailer ensure the battery switch is off, the safety latches are engaged on all lifting arms and the tongue and rear of the trailer are safely supported.

Service and Maintenance

Electric Brakes: Electric brake manual can be found on the Futura Trailers website.

The trailer brakes should be burnished-in when new by applying the brakes 20 to 30 times with an approximate 30 kph decrease in speed, eg from 50 kph to 20 kph, allowing ample time for the pads to cool between application.

Check the brake pads for wear before each tow. Adjust the brakes after the first 200 kms and at 5,000 km intervals thereafter or as use and performance requires.

To adjust the brakes.

1. Jack the wheel off the ground.
2. Remove the cover from the adjusting slot on the bottom of the brake backing plate.
3. Using a screwdriver, rotate the star-wheel of the adjuster assembly to expand the brake shoes.
4. Adjust the brake shoes out until the pressure of the linings against the drum makes the wheel very difficult to turn.
5. Rotate the star-wheel in the opposite direction until the wheel turns freely with a slight lining drag.
6. Replace the adjusting slot cover and lower the wheel to the ground. Repeat the above procedure on all brakes.



Wheel Bearing Adjustment:

Check wheel bearings for heat and excessive play at 15, 50 and 100km and before each tow.

Adjust the wheel bearings at 3,000 km intervals or as use and performance requires.

Lubricate bearings every 12 months or 10,000 kms.

To set wheel bearings:

1. Rotate the hub slowly while tightening the castle nut to approximately 50 ft/lb.
2. Back off the castle nut completely to remove the torque.
3. Turn the castle nut by hand until it is snug and line up the nearest cotter pin hole.
4. Replace the cotter pin and bend over the pin legs.
5. Check for excessive play or heat after the first 15 kms, repeat adjustment procedure if necessary.

WARNING

Failure to back off the castle nut as described may cause the bearing to run hot and be damaged. If this happens during operation, the wheel also may lock or come off, causing a risk of serious bodily harm.

Service and Maintenance

Torque Wheel Nuts:

After first 15, 50 and 100 kms, torque nuts to to 95 ft/lb. Repeat sequence before each trip or whenever a wheel is removed or replaced.

Chassis:

Keep the chassis clean and free from salt and road debris.

If the trailer has been towed on salted or grimy roads then we recommend rinsing the rigging and pulleys with fresh water to prevent debris and salt build up in the pulley bushes.

Lifting Arm:

It is important that lifting arm idler hub bearings are snug and there is no lateral movement in the lifting arms.

If there is play in the lifting arm, tighten the hub nut to 50 ft/lb, replace and bend over the cotter pin.

Winch and Rigging:

Do not overwind the winch down to avoid back winding. Keep the winch rope neat on the winch drum. If you notice the winch load up excessively when the trailer reaches the full up position, release the UP button as the control circuit may have failed.

Inspect and clean the magnetic proximity sensor located on the left rear mount beam. The sensor surface must be clean for the sensor to operate correctly.

Periodically inspect the winch rope and rigging wire for fraying. If any fraying or damage has occurred you must replace the rope or rigging wire immediately.

Lightly lubricate the rigging pulley bushes with motorcycle chain lube, lithium grease or similar, to minimise bearing noise and prolong service life.

Inspect pulley shafts as a part of regular preventive maintenance and replaced if worn.

Late Model Tow Vehicle Lighting Issue:

Some late model vehicles have sensors built into the tail light harnesses to detect when a lamp has burned out. LED trailer lighting may not work correctly when connected to these vehicles. Consult the vehicle manufacturer for a solution.

IF IN DOUBT ABOUT ANY SERVICE OR MAINTENANCE PROCEDURES PLEASE HAVE YOUR FUTURA DEALER OR A SIMILARLY TRAINED AND QUALIFIED PERSON CARRY OUT THE TASK.

Service and Maintenance Cleaning Your Super Tourer

The Super Tourer Pro is enclosed with a high tech preconstraint exterior membrane. It offers superior protection to conventional composite fabrics and requires very little maintenance.

The membrane is cleverly designed with an ultra smooth surface and anti-grip agent to resist debris.

However to maintain the appearance of your Super Tourer Pro, we recommend cleaning it when particles begin to accumulate, leaving a visible trace.



To clean your Futura Super Tourer Pro, raise your trailer to the travelling position and close all the zips.

Use a soft brush with soapy water to clean the surface of your trailer.

We recommend “Spray Nine Heavy Duty” Spray if the trailer has become particularly dirty, and requires a more thorough clean. Follow the directions on the bottle, and rinse thoroughly when finished.

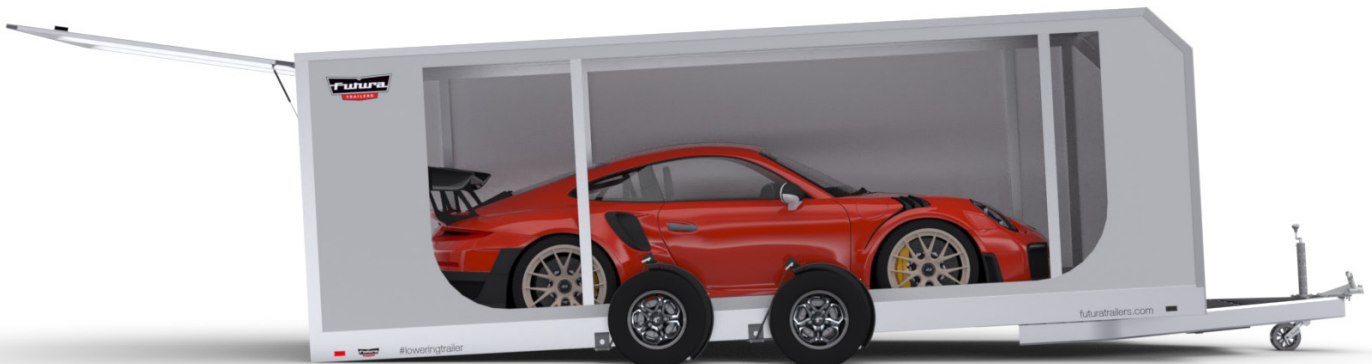

Super Tourer Zipper Lubrication: Quick Guide

Keep your Super Tourer zipper functioning smoothly with these simple steps!

Materials Needed:

Zipper lubricant, clean cloth, cotton swab (optional).

Step 1: Clean Zipper

- Brush off dirt from zipper teeth.
- For tough grime, use a damp cloth
- Dry thoroughly

Step 2: Apply Lubricant

- Use lubricant designed for zippers
- Apply a small amount along the teeth, top to bottom
- Use cotton swab for precise application
- Move slider to distribute lubricant

Step 3: Remove Excess

- Wipe away excess lubricant with a clean cloth



Maintenance Tips:

- Regularly lubricate, especially after exposure to harsh elements
- Never force a stuck zipper; lubricate to loosen
- Regular checks can prevent damage
- Store gear in a clean, dry place





FUTURA TRAILERS TWO-YEAR LIMITED WARRANTY

REGISTER YOUR PURCHASE

Registering with Futura Trailers will allow us to better serve your needs as a Futura Owner after you have purchased the trailer.

PLEASE ASSIST YOUR DEALER BY PROVIDING THE NECESSARY INFORMATION TO REGISTER YOUR TRAILER OR REGISTER ON OUR WEB SITE

<https://www.futuratrailers.com/my-futura>

E-MAIL TRAILERS@FUTURATRAILERS.COM OR PHONE +64 9 415 2563

OBTAINING WARRANTY SERVICE

To obtain service under this Limited Warranty, the Purchaser must do all of the following:

1. Prior to repairs, the Purchaser must notify Futura Trailers or one of its authorised, independent dealers, of any claimed defect within the limited warranty period or 10 days thereafter;
 - a. The last 5 digits of the VIN number of the trailer (the VIN plate is located on the left side trailer drawbar).
 - b. A clear explanation and clear, dated, photographs of the parts in question
2. Promptly return the trailer to Futura Trailers Ltd, an authorised Futura Trailers dealer, or other service agent authorised by Futura Trailers for repairs.

If you believe a defect covered by this Limited Warranty still exists after an attempted repair by an authorised Futura Trailers dealer or agent, you must contact Futura Trailers. Contact details are available on futuratrailers.com website.

LIMITED WARRANTY - STRUCTURE

Futura Trailers warrants that each FUTURA TRAILER operated by the original purchaser under normal use in the New Zealand and Australia will be free from defects in materials and workmanship for two years following the original purchase, subject to the requirements, exclusions and limitations stated below. The obligation of this warranty shall be limited to repairing or replacing any part or parts, which in the opinion of Futura Trailers are defective in materials or workmanship under normal use and service during the warranty period commencing with the date of the first retail purchase. Futura Trailers reserves the right to use new or remanufactured parts of similar quality to complete any warranty work. This limited warranty is subject to change, for the current version please visit futuratrailers.com website.

LIMITED WARRANTY PERIOD

The Limited Warranty period begins on the date the product is first sold to a purchaser. Any repairs, replacement of parts, or the undertaking of service under this Limited Warranty, does not extend the life of this Limited Warranty beyond its original expiration date from purchase.

PRIOR WRITTEN CONSENT AND RETURN OF DEFECTIVE PARTS REQUIREMENTS

No reimbursement will be made to any Dealer or Purchaser for warranty work performed without the prior written consent of Futura Trailers. Any defective part(s) may be required to be sent by prepaid freight to Futura Trailers in order to qualify for replacement or reimbursement under this Limited Warranty.

THE CONDITIONS OF THE LIMITED WARRANTY

The trailer must be kept in a safe and roadworthy condition as required for use on roads at all times. Futura Trailers reserves the right to make any warranty coverage contingent upon any trailer having an up-to-date registration and/or current Warrant of Fitness, Safety Certificate, or Certificate of Inspection as required by the relevant Country or State laws. Up-to-date trailer maintenance is required for limited warranty claims. Routine maintenance and correct use and storage are the responsibility of the Purchaser.

THIS LIMITED WARRANTY COVERS MANUFACTURING DEFECTS ONLY

The liability of Futura Trailers Ltd is limited to the cost of repair and/or replacement of the product under warranty. This Limited Warranty covers only defects in original components which arise from normal use and does not apply if the trailer has been subject to negligence, accident, abuse, misuse, improper loading, off-road use, improperly hitched, failure to provide proper maintenance, improperly stored, commercial use, or has been repaired or altered without the prior written consent of Futura Trailers.

The Limited Warranty is invalidated if the defect is caused by failure to follow instructions of correct use, misuse, neglect, lack of proper maintenance, tampering, incorrect adjustment, modification or overloading. It is invalidated if unauthorised persons carry out any alterations or repairs.

CONSEQUENTIAL LOSS OR DAMAGE IS NOT COVERED BY THIS LIMITED WARRANTY

Futura Trailers' limited warranty does not cover any consequential loss or damage resulting from the use of the trailer or any failure of the trailer or its parts. This includes but is not limited to loss of use, time, inconvenience, personal property damage or loss, loss of income, or any other type of damages, foreseen or unforeseen. Futura Trailers Ltd will not be responsible for any fees or fines incurred by the purchaser relating to any warranty claims against the manufacturer. Furthermore, any costs related to transportation, delivery charges, and freight of the affected product are not the responsibility of Futura Trailers.

THIS LIMITED WARRANTY DOES NOT PROVIDE COVERAGE FOR ANY OF THE FOLLOWING

1. Damages caused by failure to provide proper maintenance and repair, loose or improperly torqued nuts, bolts and screws (maintaining necessary tightness is the Purchaser's responsibility);
2. If the trailer is commercially used or rented out this Limited Warranty is null and void. Any commercially active trailer is covered under the Futura Trailers Limited Commercial Warranty;
3. Electrical system corrosion, corrosion resulting from damage, or corrosion that causes purely cosmetic damage, abuse or improper service;
4. Bearing failure is not covered as bearing performance is highly dependent on Purchaser's diligence in maintaining greasing and adjusting;
5. Damages caused by failure to check and torque wheel lug nuts properly;
6. Defects or damage caused by, in whole or in part, or in any way related to; accidents, misuse including off-road use, or negligence;
7. Damage due to the addition of weight to the trailer that causes the trailer's total weight to exceed manufacturer-stated specifications, trailer weight ratings or to cause improper towing because of improper load balance;
8. Damage due to carrying anything other than pneumatic rubber-tyre vehicles, with all tyres in contact with the trailer deck.
9. Jack wheels are not covered as jack wheels are easily damaged due to incorrect use of the jack.
10. Any part or component of the trailer that was not manufactured or installed by Futura Trailers;
11. After-market equipment or accessories installed on the trailer after completion of manufacture by Futura Trailers, or any defects or damage caused by such items;
12. Any work performed or options installed by individuals or organisations other than Futura Trailers, a repair agent with written authority from Futura Trailers or the Dealer who sold the trailer when new.
13. Alteration or modification of the trailer except such alterations or modifications approved in writing by Futura Trailers, including but not limited to welding of the chassis;
14. Normal deterioration of anodising, zinc plating, galvanising and powder-coating due to wear or exposure, including but not limited to rust, corrosion, oxidation, scratches and cosmetic blemishes;
15. Normal maintenance and service items shall not be replaced due to wear (items include, but are not limited to bearings, bushes, sheaves, brakes, rigging cable and rope, brake linings, latches and battery);
16. Failure to properly maintain or service the trailer, including but not limited to the maintenance of lubricants;
17. Failure to seek and obtain repairs promptly;
18. Selection, use and operation of any hitch assembly;
19. Use of incorrect or altered hitch ball or improper latching;
20. Trailers not purchased through an authorised Dealer of Futura Trailers products and trailers purchased directly or indirectly through auction, salvage, repossession or other non-customary sale means;
21. Acts of god or other environmental conditions such as lightning, hail, salt or other chemicals in the atmosphere;
22. Condensation and the results of condensation including water damage;
23. Damage incurred by excessive snow loading.
24. Damage caused by de-icing agents or other chemicals applied to the trailer;
25. Failure to use reasonable efforts to mitigate damage caused by defects;
26. Any damage caused to the loaded vehicle or tow vehicle due to defective materials or workmanship;
27. Acts or omissions of any person or entity other than Futura Trailers;
28. Failure to comply with the instructions outlined in any Owner's Manual or guide provided or made available online by Futura Trailers.

OTHER EXCLUSIONS NOT COVERED BY THIS LIMITED WARRANTY

The Futura Trailers trailer is engineered to properly handle the gross vehicle load rating on the certification label. Load distribution has a definite effect on the towing characteristics and attitudes of the trailer. There are limits to the amount of load that can be safely transported depending upon speed and road conditions - and reasonable cause to believe these factors have been exceeded could void the Futura Trailers' Limited Warranty. For additional information on the loading of your trailer, consult your Owner's Manual or gross vehicle weight rating plate.

The axle is manufactured to a tolerance of 1-degree camber and 3mm toe-in. These tolerances will only change if the trailer is subjected to abuse, such as dropping off a sharp berm, striking a curb or hitting a deep hole in the road. Such damage could be considered as resulting from an accident in which risks are not covered under the Limited Warranty. Abnormal tyre wear and/or wheel alignment resulting from such damage is not covered under the terms of the Limited Warranty.

In addition to the above exclusions, Futura Trailers expressly excludes from this Limited Warranty the following: tow vehicle wiring, loss of time, inconvenience, loss of use of the trailer, rental of substitute equipment, loss of revenues or other commercial loss and tow vehicle wear or damage.

The trailer covered by this Limited Warranty is designed to be towed by a vehicle with up to one (1) ton capacity and any use of the trailer that exceeds the tow vehicle manufacturer's specific limitations are not covered by this Limited Warranty.

LIMITATION

Futura Trailers' responsibility under this Limited Warranty shall be limited to the repair or replacement of parts at the Futura Trailers facility, Futura Trailers Dealer facility or for a reasonable allowance, at another place approved in writing by Futura Trailers. If such a warranty fails because attempts at repair are not completed within a reasonable time, or it fails for any other reason, any damages are limited to the lesser of either the cost of the needed repairs or reduction in the market value of the trailer caused by the lack of repairs.

Replacement parts are warranted for the balance of the original Limited Warranty period. Replacement parts are sent to whoever is responsible for the repair. Futura Trailers will not be responsible for improper repairs made. Futura Trailers will not be responsible for non-authorized replacement parts used in repairs. Products or parts produced by another manufacturer and distributed by Futura Trailers will be covered by the respective manufacturer's warranty.

Futura Trailers may direct you to an authorized Futura Trailers Dealer or repairer, or for NZ customers, may request that you bring your trailer to the Futura Trailers facility Auckland.

REPAIRS UNDER LIMITED WARRANTY

The customer must provide Futura Trailers with a reasonable opportunity to repair, and reasonable access to the product for service/repair. Limited Warranty claims shall be made by delivering the product for inspection to Futura Trailers facility or with prior written approval to one of its designated pre-approved agents to service/repair the product. The Purchaser in that case shall pay for all related transportation charges and or travel time. If the service/repair provided is not covered by this Limited Warranty, the Purchaser shall also pay for all related labour and materials, and any other expenses associated with that service/repair. Purchaser shall not unless arranged or requested by Futura Trailers send the product or parts of the product directly to Futura Trailers without prior arrangements.

DISCLAIMERS

This Limited Warranty is expressly in lieu of any other warranty not expressly provided herein which but for this provision might arise by operation of law, including any express warranties made outside this Limited Warranty, implied warranties of merchantability, implied warranties of fitness for a particular purpose and any breach of contract. These warranties are hereby expressly excluded and disclaimed. If they cannot be disclaimed, any implied warranties of merchantability and fitness for a particular purpose are expressly limited to a term of two (2) years, unless applicable laws provide for otherwise.

Under no circumstance shall Futura Trailers Ltd or its agents and dealers be liable to the purchaser or any other person for any special, incidental or consequential loss or damages, whether arising out of breach of warranty, breach of contract, tort or otherwise, unless laws provide for otherwise.

No one, including authorised Futura Trailers Dealers, is authorised to make further or additional warranties on behalf of Futura Trailers. Authorised repairs do not extend the term of this Limited Warranty. Futura Trailers reserves the right to make changes to this document without notice.

CONSEQUENTIAL LOSS OR DAMAGE DISCLAIMER

Futura Trailers Ltd hereby disclaim any and all incidental and consequential loss or damages arising out of or relating to the use of the trailer or any failure of the trailer or any part, including but not limited to expenses for loss of time, loss of pay, loss of use, inconvenience, commercial loss (including lost profits), towing charges, bus fares, vehicle rental, service call charges, fuel expenses, incidental charges such as telephone calls, and expenses for lodging. This disclaimer is independent of any failure of the essential purpose of any warranties provided with a trailer and shall survive any determination that a warranty failed of its essential purpose. Some states do not allow the exclusion or limitation of incidental or consequential loss or damages, so the above limitation or exclusion may not apply to you.

Futura Trailers is not responsible for costs relating to transportation, delivery charges and freight of the affected product.

Futura Trailers Ltd will not be responsible for consequential, incidental, contingent liabilities, special or indirect damages of any kind which may be incurred as a result of any defect in material or workmanship or the failure of any parts to operate properly, including, but not limited to, loss of use, loss of time, inconvenience, personal property loss or damage, loss of income from the use of the said product, or any other type of damages, general or specific, foreseen or unforeseen, or in any way, Futura Trailers will not be responsible for any fees or fines incurred by purchaser relating to any warranted claims against the manufacturer.

THIS LIMITED WARRANTY IS TRANSFERABLE FROM THE ORIGINAL PURCHASER UPON NOTIFICATION TO AND ACCEPTANCE BY FUTURA TRAILERS.

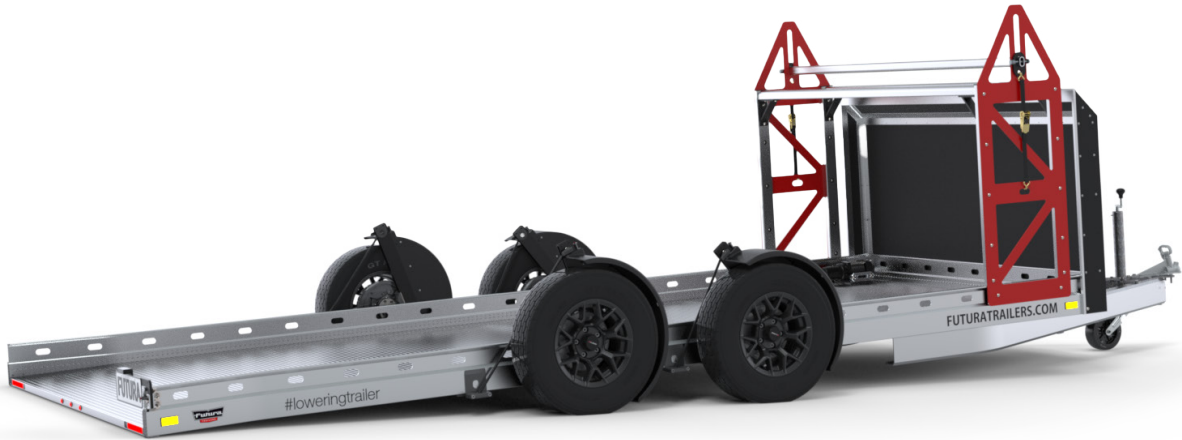

Email: trailers@futuratrailers.com
Phone: +64 9 415 2563

FUTURA TRAILERS LTD
42 Westpoint Drive
Auckland
New Zealand



ENGINEERED TO BE EFFORTLESS